

# TT40 MIXER TANK

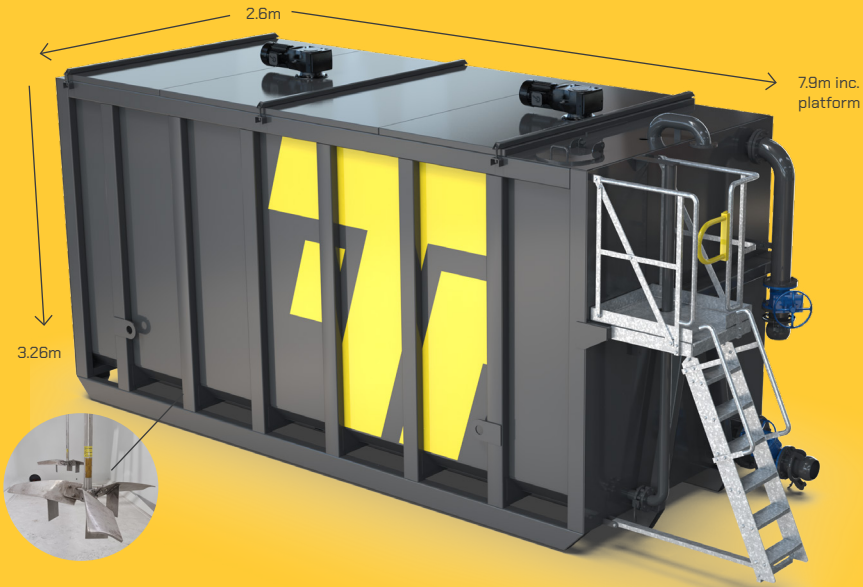

**TECHNICAL**

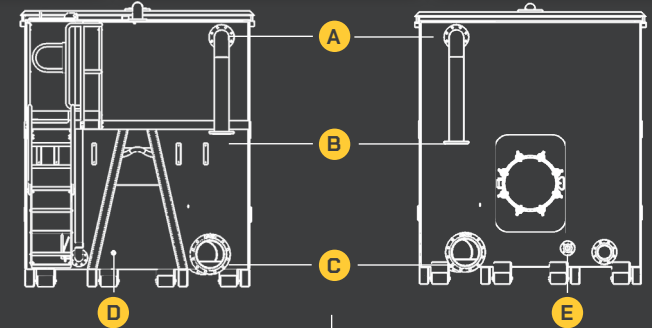

	Front	Rear
<b>Connections</b>	<p><b>A</b> High level 6 inch (150mm) connection</p> <p><b>B</b> Fill Pipe up to 6 inch (150mm)</p> <p><b>C</b> Sump discharge up to 12 inch (300mm)</p> <p><b>D</b> Sampling take off point 1 inch (25mm)</p>	<p>High level 6 inch (150mm) connection</p> <p>Fill Pipe up to 6 inch (150mm)</p> <p>Sump discharge up to 12 inch (300mm)</p> <p><b>E</b> 2 inch flange</p>
	Valve + Coupling connections tailored to meet your site-specific requirements	
<b>Vent</b>	4 inch top vent (on enclosed roof versions)	
<b>Mounted Inspection Hatch</b>	Visual contents inspection, accessible from top access platform	
<b>Mixers</b>	2nr 4kw 71 rpm mixers	
<b>Required Power Supply</b>	5 pin plug, 3 phase 32 Amp 14.8 Amp FLC (approx.)	
<b>Access Platform</b>	Fold out access platform c/w steps, handrails, safety swing gate	
<b>Contents Gauging</b>	Sight tube Radar (Telemetric)	
<b>Manway Access</b>	Low level, quick release, easy access hinged manlid	
<b>Internal Coating</b>	Chemical resistant epoxy lining (customer to supply MSDS for tank contents compatibility checking)	

**MEASUREMENTS & WEIGHT**

<b>Length</b>	7,900mm including platform	<b>Volume</b>	40,000 Litres
<b>Width</b>	2,600mm		40m3
<b>Height</b>	3,260mm		8,800 UK Gallons
<b>Weight (empty)</b>	7200kg (approx.)	<b>Weight (loaded)</b>	52000kg (approx.) - based on a liquid of SG1.12
<b>Ground Pressure</b>	225 kPa (approx.) - based on a liquid of SG1.12		

**MOBILISATION**

Roll-On / Roll-Off, self-offload
Hiab self-offload
Crane lift via easy access, low level lifting points

**APPLICATIONS**

Industrial services	Contract de-watering
Manufacturing	Effluent processing
Chemical decom	Wastewater treatment