

# TT70 MIXER TANK

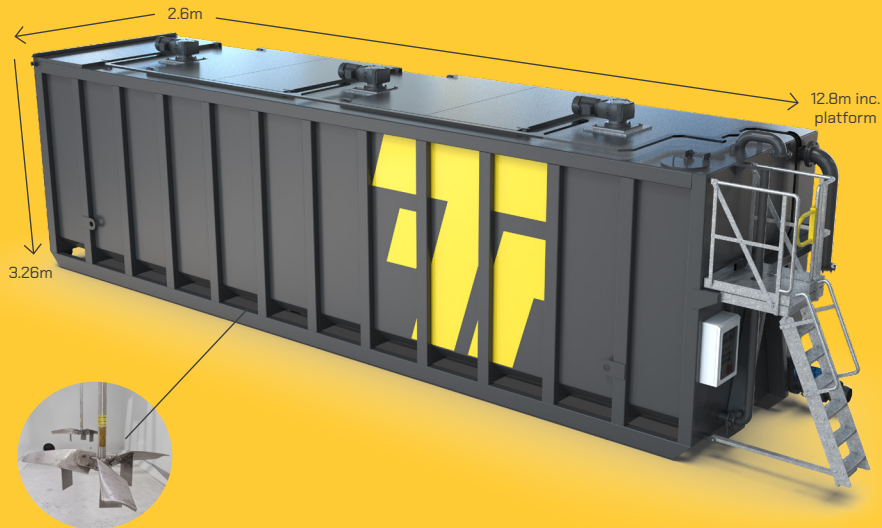

## MEASUREMENTS & WEIGHT

<b>Length</b>	12,800mm including platform	<b>Volume</b>	70,000 Litres
<b>Width</b>	2,600mm		70m <sup>3</sup>
<b>Height</b>	3,260mm		15,400 UK Gallons
<b>Weight (empty)</b>	11000kg (approx.)	<b>Weight (loaded)</b>	89400kg (approx.) - based on a liquid of SG1.12
<b>Ground Pressure</b>	219 kPa (approx.) - based on a liquid of SG1.12		

## MOBILISATION

Roll-On / Roll-Off, self-offload
Hiab self-offload
Crane lift via easy access, low level lifting points

## APPLICATIONS

Industrial services	Contract de-watering
Manufacturing	Effluent processing
Chemical decom	Wastewater treatment



## TECHNICAL

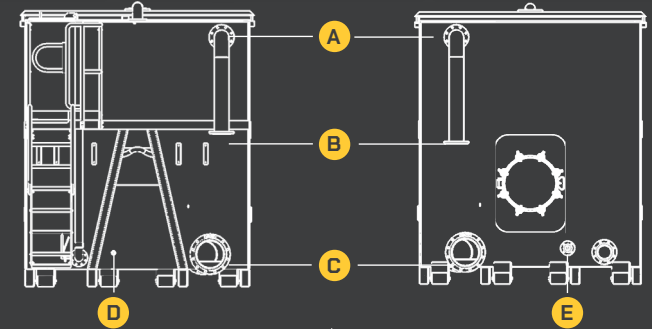

	Front	Rear
<b>Connections</b>	<b>A</b> High level 6 inch (150mm) connection <b>B</b> Fill Pipe up to 6 inch (150mm) <b>C</b> Sump discharge up to 12 inch (300mm) <b>D</b> Sampling take off point 1 inch (25mm)	<b>A</b> High level 6 inch (150mm) connection <b>B</b> Fill Pipe up to 6 inch (150mm) <b>C</b> Sump discharge up to 12 inch (300mm) <b>E</b> 2 inch flange
	Valve + Coupling connections tailored to meet your site-specific requirements	
<b>Vent</b>	4 inch top vent (on enclosed roof versions)	
<b>Mounted Inspection Hatch</b>	Visual contents inspection, accessible from top access platform	
<b>Mixers</b>	3nr 4kw 71 rpm mixers	
<b>Required Power Supply</b>	5 pin plug, 3 phase 32 Amp 21.9 Amp FLC (approx.)	
<b>Access Platform</b>	Fold out access platform c/w steps, handrails, safety swing gate	
<b>Contents Gauging</b>	Sight tube Radar (Telemetric)	
<b>Manway Access</b>	Low level, quick release, easy access hinged manlid	
<b>Internal Coating</b>	Chemical resistant epoxy lining (customer to supply MSDS for tank contents compatibility checking)	