



SIMPLIFYING LIQUID CONTAINMENT

PRODUCT GUIDE

ABOUT US

TerraTank supplies liquid storage tanks and associated equipment, supporting both planned and reactive projects.

As the market leader in the supply of modular and scalable tank solutions, TerraTank assists customers with flexible procurement options that align with operational and commercial requirements.

Our service promise ensures that you benefit from simple transactional processes, reliable quality control procedures and a dedicated logistics team to carry out delivery and installation efficiently.



SIMPLIFYING LIQUID CONTAINMENT.



MODULAR

Our modular fleet of tanks feature a range of capacities, enabling them to be manifolded for seamless, large-scale storage.



PLUG-&-PLAY

Our agile team and in-house logistics allow for rapid deployment of equipment with minimal setup, reducing downtime on site.



VERSATILE

We offer a wide variety of configurations and connections, with an optimised footprint to best suit your requirements.

Specifications are indicative and may vary by configuration and region. Datasheets are subject to change and may be superseded at any time. Dimensions are approximate and must be verified prior to transportation or volume calculations.

CONTENTS

ABOUT US	02 - 03
BULK LINED STORAGE TANKS	
TTP10 & TTPW10 VERTICAL TANK	04 - 05
TT03 CENTRATE TANK WITH INTEGRATED PUMP	06 - 07
TT10 CENTRATE TANK WITH INTEGRATED PUMP	08 - 09
TT20 ENCLOSED & OPEN TOP	10 - 11
TT30 ENCLOSED & OPEN TOP	12 - 13
TT40 ENCLOSED & OPEN TOP	14 - 15
TT70 ENCLOSED & OPEN TOP	16 - 17
MIXER TANKS	
TT40 MIXER TANK	18 - 19
TT70 MIXER TANK	20 - 21
HEATER TANKS	
TT70 HEATER TANK	22 - 23
HEATER MIXER TANKS	
TT70 HEATER MIXER TANK	24 - 25
AERATION TANKS	
TT40 AERATION TANK	26 - 27
TT70 AERATION TANK	28 - 29
WEIR TANKS	
TT60-W WEIR TANK	30 - 31
TANK EQUIPMENT AND ACCESSORIES	
INDUSTRY SECTORS	32 - 35
INDUSTRY SECTORS	36 - 37

TTP10 VERTICAL TANK

TTPW10 POTABLE WATER VERTICAL TANK



MEASUREMENTS & WEIGHT

Diameter	2,400mm
Height	2,500mm
Skid Frame	2500mm x 2800mm
Weight (empty)	3500kg (approx.)
Ground Pressure	102 kPa (approx.) - based on a liquid of SG1.12

Volume	10,000 Litres
	10m ³
	2,200 UK Gallons
Weight (loaded)	14700kg (approx.) - based on a liquid of SG1.12

MOBILISATION

Hiab self-offload

Forklift offload

Mounted on skid frame

TECHNICAL

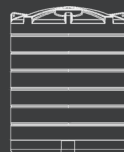

Valve + Coupling connections tailored to meet your site-specific requirements

MEASUREMENTS & WEIGHT

Diameter	2,400mm
Height	2,500mm
Skid Frame	2500mm x 2800mm
Weight (empty)	3500kg (approx.)
Ground Pressure	102 kPa (approx.) - based on a liquid of SG1.12

Volume	10,000 Litres
	10m ³
	2,200 UK Gallons
Weight (loaded)	14700kg (approx.) - based on a liquid of SG1.12

MOBILISATION

Hiab self-offload

Forklift offload

Mounted on skid frame

TECHNICAL

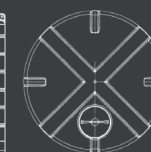
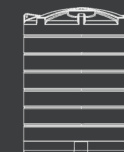

Valve + Coupling connections tailored to meet your site-specific requirements

TT03 CENTRATE TANK WITH INTEGRATED PUMP OPTION



MEASUREMENTS & WEIGHT

Length	3,100mm	Volume	2,500 Litres
Width	1,450mm		2.5m ³
Height	1,200mm		550 UK Gallons
Weight (empty)	1500kg (approx.)	Weight (loaded)	3400kg (approx.) - based on a liquid of SG1.12
Ground Pressure	48 kPa (approx.) - based on a liquid of SG1.12		

MOBILISATION

Hiab self-offload
Crane lift via easy access, low level lifting points

APPLICATIONS

HP jetting	Industrial services
Pipeline testing	Site buffer storage
Chemical decom	Shutdowns & turnarounds



TECHNICAL

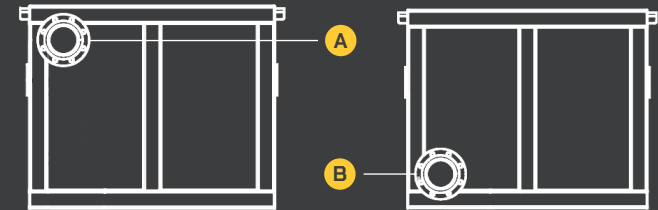

	Front	Rear
Connections	<p>A Fill up to 6 inch (150mm)</p> <p>B</p>	Sump discharge up to 6 inch (150mm)
Internal Coating	Valve + Coupling connections tailored to meet your site-specific requirements	
	Chemical resistant epoxy lining (customer to supply MSDS for tank contents compatibility checking)	

INTEGRATED PUMP SPECIFICATION

Pump Type	Submersible Pump Mounted on pedestal foot 4" PN16 Outlet - 80mm passage for solids 100 M3/hour @ 8Mtr Head 80 M3/hour @ 10Mtr Head 160 M3/hour @ 4Mtr Head
Control Panel	Power Supply 415V 32Amp High / low float operation High level alarm High level remote inhibit

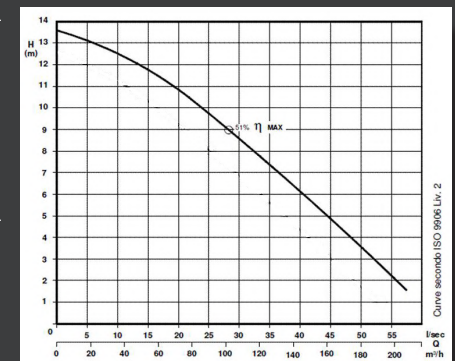

TT10 CENTRATE TANK WITH INTEGRATED PUMP



MEASUREMENTS & WEIGHT

Length	3,700mm	Volume	10,000 Litres
Width	2,600mm		10m ³
Height	1,500mm		2,200 UK Gallons
Weight (empty)	2500kg (approx.)	Weight (loaded)	13700kg (approx.) - based on a liquid of SG1.12
Ground Pressure	59 kPa (approx.) - based on a liquid of SG1.12		

MOBILISATION

Hiab self-offload
Crane lift via easy access, low level lifting points

APPLICATIONS

HP jetting	Industrial services
Pipeline testing	Site buffer storage
Chemical decom	Centrate storage



TECHNICAL

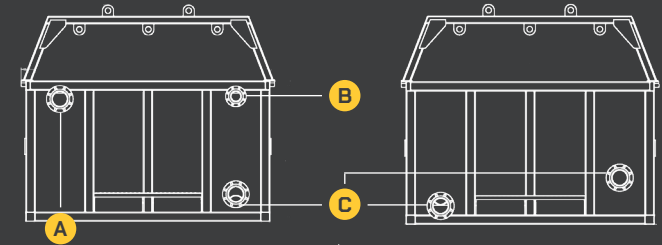

	Front	Rear
Connections	<p>A Fill up to 6 inch (150mm)</p> <p>B Fill up to 4 inch (100mm)</p> <p>C Sump discharge up to 6 inch (150mm)</p>	Sump discharge up to 6 inch (150mm)
	Valve + Coupling connections tailored to meet your site-specific requirements	
Access Platform	Integral built in step to enable visibility of tank contents	
Draining	Internal sloped floor for efficient draining and cleaning	
Internal Coating	Chemical resistant epoxy lining (customer to supply MSDS for tank contents compatibility checking)	

INTEGRATED PUMP SPECIFICATION

Pump Type	Submersible Pump Mounted on pedestal foot 4" PN16 Outlet - 80mm passage for solids 100 M3/hour @ 8Mtr Head 80 M3/hour @ 10Mtr Head 160 M3/hour @ 4Mtr Head
Control Panel	Power Supply 415V 32Amp High / low float operation High level alarm High level remote inhibit

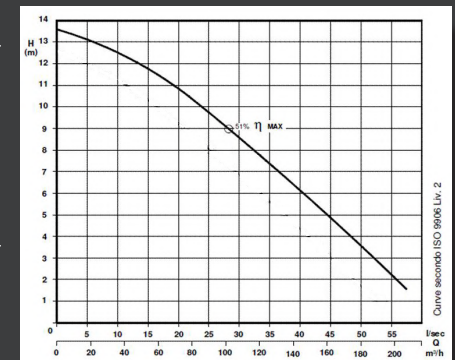

TT20 ENCLOSED & OPEN TOP BULK STORAGE TANK



MEASUREMENTS & WEIGHT

Length	5,600mm including platform
Width	2,800mm
Height	3,400mm
Weight (empty)	3500kg (approx.)
Ground Pressure	110 kPa (approx) - based on a liquid of SG1.12

MOBILISATION

Hiab self-offload
Crane lift via easy access, low level lifting points

Volume	20,000 Litres
	20m ³
	4,400 UK Gallons
Weight (loaded)	25900kg (approx.) - based on a liquid of SH1.12

APPLICATIONS

HP jetting	Industrial services
Pipeline testing	Site buffer storage
Chemical decom	Shutdowns & turnarounds



TECHNICAL

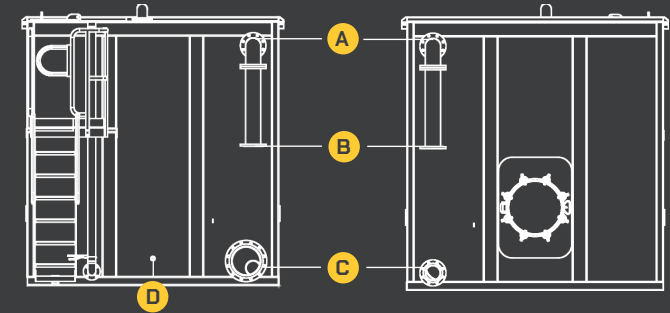

	Front	Rear
Connections	A High level 6 inch (150mm) connection	High level 6 inch (150mm) connection
	B Fill Pipe up to 6 inch (150mm)	Fill Pipe up to 6 inch (150mm)
	C Sump discharge up to 12 inch (300mm)	Sump discharge up to 6 inch (150mm)
	D Sampling take off point 1 inch (25mm)	
	Valve + Coupling connections tailored to meet your site-specific requirements	
Vent	4 inch top vent (on enclosed roof versions)	
Mounted Inspection Hatch	Visual contents inspection, accessible from top access platform	
Top Access Platform	Fold out access platform c/w steps, handrails, safety swing gate	
Contents Gauging	Sight tube Radar (Telemetric)	
Manway Access	Low level, quick release, easy access hinged manlid	
Internal Coating	Chemical resistant epoxy lining (customer to supply MSDS for tank contents compatibility checking)	

TT30 ENCLOSED & OPEN TOP BULK STORAGE TANK

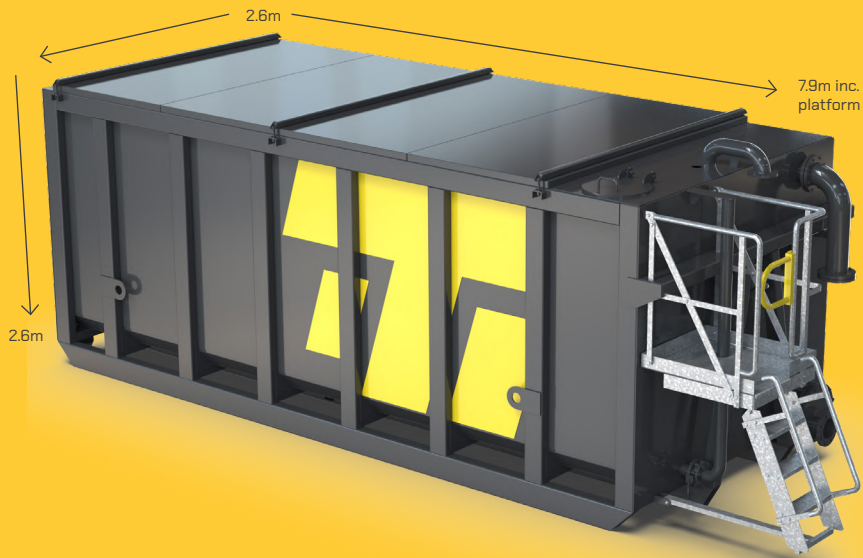

MEASUREMENTS & WEIGHT

Length	7,900mm including platform
Width	2,600mm
Height	2,600mm
Weight (empty)	5300kg (approx.)
Ground Pressure	168 kPa (approx.) - based on a liquid of SG1.12

Volume	30,000 Litres
	30m ³
	6,600 UK Gallons
Weight (loaded)	38900kg (approx.) - based on a liquid of SG1.12

MOBILISATION

Roll-On / Roll-Off self-offload
Hiab self-offload
Crane lift via easy access, low level lifting points

APPLICATIONS

HP jetting	Industrial services
Pipeline testing	Site buffer storage
Chemical decom	Shutdowns & turnarounds

TECHNICAL

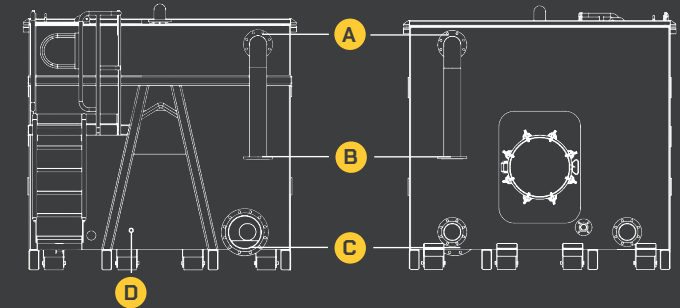

	Front	Rear
Connections	A High level 6 inch (150mm) connection	High level 6 inch (150mm) connection
	B Fill Pipe up to 6 inch (150mm)	Fill Pipe up to 6 inch (150mm)
	C Sump discharge up to 12 inch (300mm)	Sump discharge up to 6 inch (150mm)
	D Sampling take off point 1 inch (25mm)	
	Valve + Coupling connections tailored to meet your site-specific requirements	
Vent	4 inch top vent (on enclosed roof versions)	
Mounted Inspection Hatch	Visual contents inspection, accessible from top access platform	
Top Access Platform	Fold out access platform c/w steps, handrails, safety swing gate	
Contents Gauging	Sight tube Radar (Telemetric)	
Manway Access	Low level, quick release, easy access hinged manlid	
Internal Coating	Chemical resistant epoxy lining (customer to supply MSDS for tank contents compatibility checking)	

TT40 ENCLOSED & OPEN TOP BULK STORAGE TANK

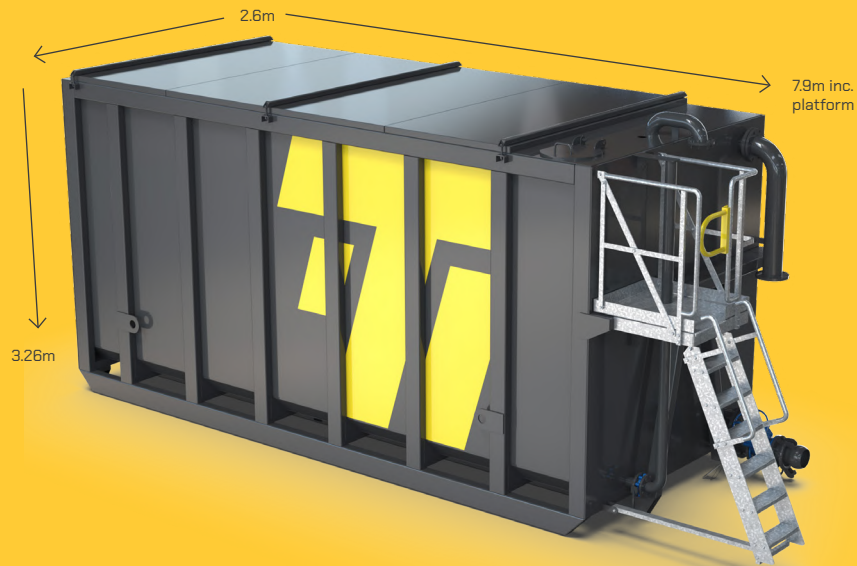

MEASUREMENTS & WEIGHT

Length	7,900mm including platform
Width	2,600mm
Height	3,260mm
Weight (empty)	6300kg (approx.)
Ground Pressure	93 kPa (approx.) - based on a liquid of SG1.12

Volume	40,000 Litres
	40m ³
	8,800 UK Gallons
Weight (loaded)	51100kg (approx.) - based on a liquid of SG1.12

MOBILISATION

Roll-On / Roll-Off, self-offload
Hiab self-offload
Crane lift via easy access, low level lifting points

APPLICATIONS

HP jetting	Industrial services
Pipeline testing	Environmental incidents
Chemical decom	Shutdowns & turnarounds

TECHNICAL

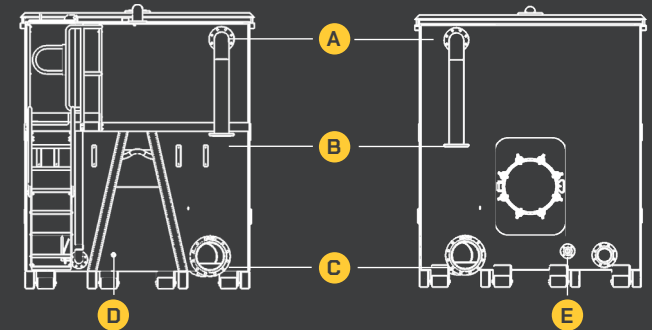

	Front	Rear
Connections	A High level 6 inch (150mm) connection B Fill Pipe up to 6 inch (150mm) C Sump discharge up to 12 inch (300mm) D Sampling take off point 1 inch (25mm)	A High level 6 inch (150mm) connection B Fill Pipe up to 6 inch (150mm) C Sump discharge up to 12 inch (300mm) E 2 inch flange
	Valve + Coupling connections tailored to meet your site-specific requirements	
Vent	4 inch top vent (on enclosed roof versions)	
Mounted Inspection Hatch	Visual contents inspection, accessible from top access platform	
Top Access Platform	Fold out access platform c/w steps, handrails, safety swing gate	
Contents Gauging	Sight tube Radar (Telemetric)	
Manway Access	Low level, quick release, easy access hinged manlid	
Internal Coating	Chemical resistant epoxy lining (customer to supply MSDS for tank contents compatibility checking)	

TT70 ENCLOSED & OPEN TOP BULK STORAGE TANK



MEASUREMENTS & WEIGHT

Length	12,800mm including platform	Volume	70,000 Litres
Width	2,600mm		70m ³
Height	3,260mm		15,400 UK Gallons
Weight (empty)	10000kg (approx.)	Weight (loaded)	88400kg (approx.) - based on a liquid of SG1.12
Ground Pressure	215 kPa (approx.) - based on a liquid of SG1.12		

MOBILISATION

Roll-On / Roll-Off, self-offload
Hiab self-offload
Crane lift via easy access, low level lifting points

APPLICATIONS

HP jetting	Industrial services
Pipeline testing	Environmental incidents
Chemical decom	Shutdowns & turnarounds



TECHNICAL

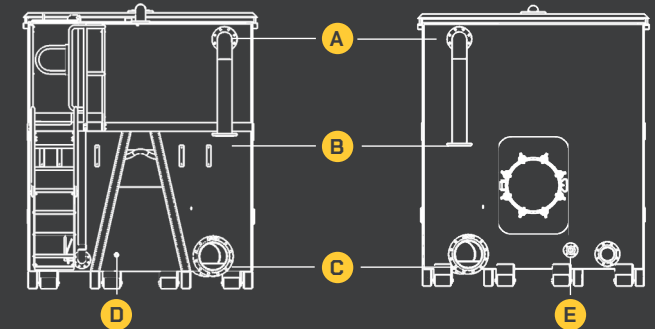

	Front	Rear
Connections	<ul style="list-style-type: none"> A High level 6 inch (150mm) connection B Fill Pipe up to 6 inch (150mm) C Sump discharge up to 12 inch (300mm) D Sampling take off point 1 inch (25mm) 	<ul style="list-style-type: none"> High level 6 inch (150mm) connection Fill Pipe up to 6 inch (150mm) Sump discharge up to 12 inch (300mm) E 2 inch flange
	Valve + Coupling connections tailored to meet your site-specific requirements	
Vent	4 inch top vent (on enclosed roof versions)	
Mounted Inspection Hatch	Visual contents inspection, accessible from top access platform	
Top Access Platform	Fold out access platform c/w steps, handrails, safety swing gate	
Contents Gauging	Sight tube Radar (Telemetric)	
Manway Access	Low level, quick release, easy access hinged manlid	
Internal Coating	Chemical resistant epoxy lining (customer to supply MSDS for tank contents compatibility checking)	

TT40 MIXER TANK

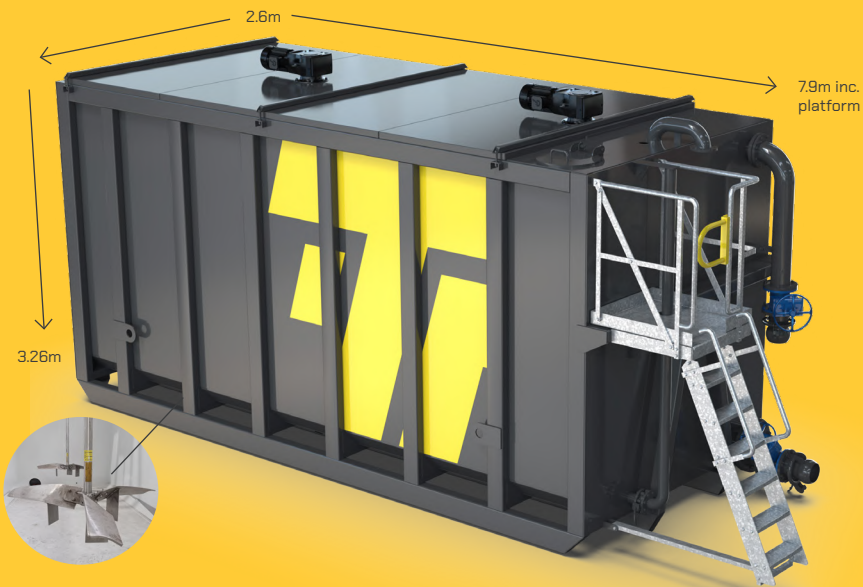

MEASUREMENTS & WEIGHT

Length	7,900mm including platform
Width	2,600mm
Height	3,260mm
Weight (empty)	7200kg (approx.)
Ground Pressure	225 kPa (approx.) - based on a liquid of SG1.12

MOBILISATION

Roll-On / Roll-Off, self-offload
Hiab self-offload
Crane lift via easy access, low level lifting points

Volume	40,000 Litres
	40m ³
	8,800 UK Gallons
Weight (loaded)	52000kg (approx.) - based on a liquid of SG1.12

APPLICATIONS

Industrial services	Contract de-watering
Manufacturing	Effluent processing
Chemical decom	Wastewater treatment



TECHNICAL

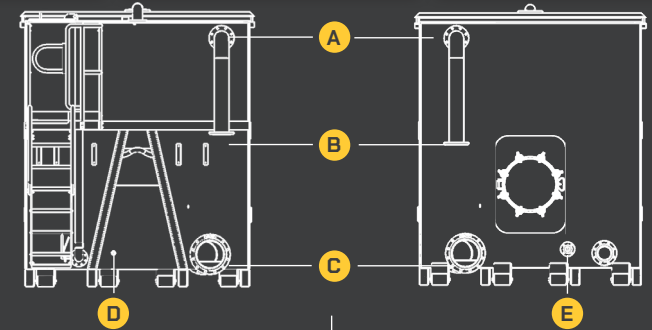

	Front	Rear
Connections	<ul style="list-style-type: none"> A High level 6 inch (150mm) connection B Fill Pipe up to 6 inch (150mm) C Sump discharge up to 12 inch (300mm) D Sampling take off point 1 inch (25mm) 	<ul style="list-style-type: none"> E 2 inch flange
	Valve + Coupling connections tailored to meet your site-specific requirements	
Vent	4 inch top vent (on enclosed roof versions)	
Mounted Inspection Hatch	Visual contents inspection, accessible from top access platform	
Mixers	2nr 4kw 71 rpm mixers	
Required Power Supply	5 pin plug, 3 phase 32 Amp 14.8 Amp FLC (approx.)	
Access Platform	Fold out access platform c/w steps, handrails, safety swing gate	
Contents Gauging	Sight tube Radar (Telemetric)	
Manway Access	Low level, quick release, easy access hinged manlid	
Internal Coating	Chemical resistant epoxy lining (customer to supply MSDS for tank contents compatibility checking)	

TT70 MIXER TANK

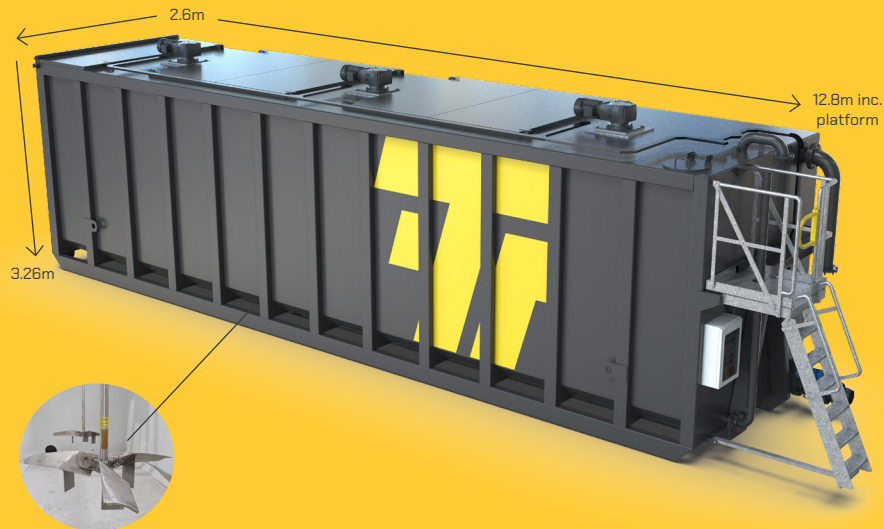

MEASUREMENTS & WEIGHT

Length	12,800mm including platform	Volume	70,000 Litres
Width	2,600mm		70m ³
Height	3,260mm		15,400 UK Gallons
Weight (empty)	11000kg (approx.)	Weight (loaded)	89400kg (approx.) - based on a liquid of SG1.12
Ground Pressure	219 kPa (approx.) - based on a liquid of SG1.12		

MOBILISATION

Roll-On / Roll-Off, self-offload
Hiab self-offload
Crane lift via easy access, low level lifting points

APPLICATIONS

Industrial services	Contract de-watering
Manufacturing	Effluent processing
Chemical decom	Wastewater treatment



TECHNICAL

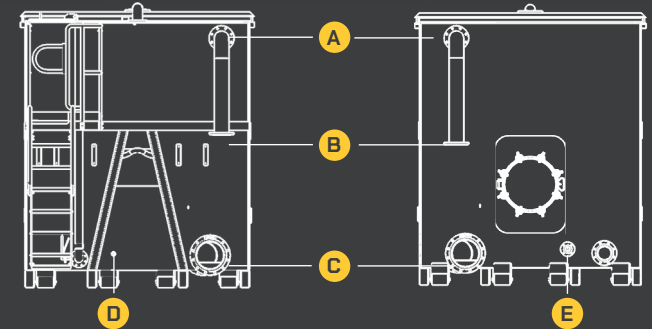

	Front	Rear
Connections	<ul style="list-style-type: none"> A High level 6 inch (150mm) connection B Fill Pipe up to 6 inch (150mm) C Sump discharge up to 12 inch (300mm) D Sampling take off point 1 inch (25mm) 	<ul style="list-style-type: none"> High level 6 inch (150mm) connection Fill Pipe up to 6 inch (150mm) Sump discharge up to 12 inch (300mm) E 2 inch flange
	Valve + Coupling connections tailored to meet your site-specific requirements	
Vent	4 inch top vent (on enclosed roof versions)	
Mounted Inspection Hatch	Visual contents inspection, accessible from top access platform	
Mixers	3nr 4kw 71 rpm mixers	
Required Power Supply	5 pin plug, 3 phase 32 Amp 21.9 Amp FLC (approx.)	
Access Platform	Fold out access platform c/w steps, handrails, safety swing gate	
Contents Gauging	Sight tube Radar (Telemetric)	
Manway Access	Low level, quick release, easy access hinged manlid	
Internal Coating	Chemical resistant epoxy lining (customer to supply MSDS for tank contents compatibility checking)	

TT70 HEATER TANK



MEASUREMENTS & WEIGHT

Length	12,800mm including platform	Volume	70m ³
Width	2,600mm		15,400 UK Gallons
Height	3,260mm	Weight (loaded)	88900kg (approx.) - based on a liquid of SG1.12
Weight (empty)	10500kg (approx.)		
Ground Pressure	216 kPa (approx.) - based on a liquid of SG1.12		

MOBILISATION

Roll-On / Roll-Off, self-offload

Hiab self-offload

Crane lift via easy access, low level lifting points

APPLICATIONS

Efficient heat transfer for projects that require heating, or temperature regulation of liquids in large volumes

Chemical decom Industrial services



TECHNICAL

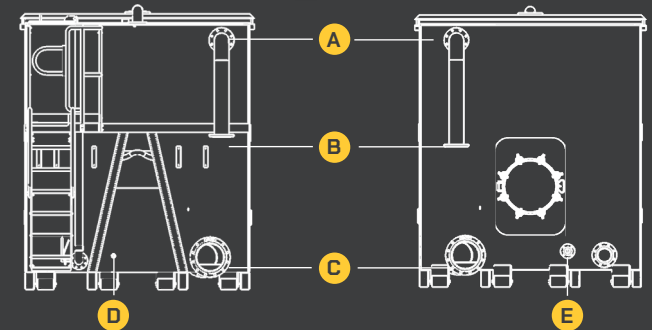

	Front	Rear
Connections	<p>A High level 6 inch (150mm) connection</p> <p>B Fill Pipe up to 6 inch (150mm)</p> <p>C Sump discharge up to 12 inch (300mm)</p> <p>D Sampling take off point 1 inch (25mm)</p>	<p>High level 6 inch (150mm) connection</p> <p>Fill Pipe up to 6 inch (150mm)</p> <p>Sump discharge up to 12 inch (300mm)</p> <p>E 2 inch flange for heating</p>
	Valve + Coupling connections tailored to meet your site-specific requirements	
Vent	4 inch top vent (on enclosed roof versions)	
Mounted Inspection Hatch	Visual contents inspection, accessible from top access platform	
Access Platform	Fold out access platform c/w steps, handrails, safety swing gate	
Contents Gauging	Sight tube Radar (Telemetric)	
Heating	2 inch steam tubes (manifold pattern) 11.6m ² surface area *	
Manway Access	Low level, quick release, easy access hinged manlid	
Internal Coating	Chemical resistant epoxy lining (customer to supply MSDS for tank contents compatibility checking)	

*steam boiler required

TT70 HEATER MIXER TANK

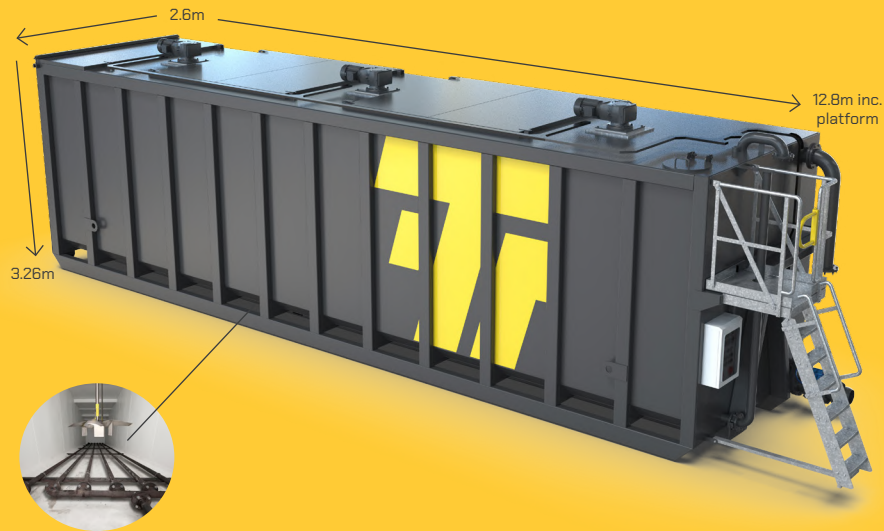

MEASUREMENTS & WEIGHT

Length	12,800mm including platform
Width	2,600mm
Height	3,260mm
Weight (empty)	11000kg (approx.)
Ground Pressure	219 kPa (approx.) - based on a liquid of SG1.12

MOBILISATION

Roll-On / Roll-Off, self-offload

Hiab self-offload

Crane lift via easy access, low level lifting points

Volume	70,000 Litres
	70m ³
	15,400 UK Gallons
Weight (loaded)	89400kg (approx.) - based on a liquid of SG1.12

APPLICATIONS

Efficient for mixing and heating of large liquid volumes for projects that require breaking down of suspended solids and temp. regulation

Chemical decom Industrial services



TECHNICAL

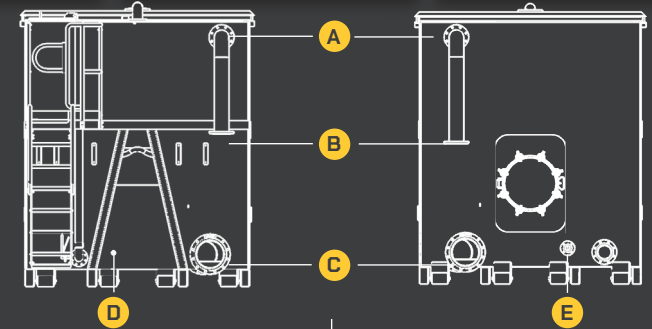

	Front	Rear
Connections	A High level 6 inch (150mm) connection	High level 6 inch (150mm) connection
	B Fill Pipe up to 6 inch (150mm)	Fill Pipe up to 6 inch (150mm)
	C Sump discharge up to 12 inch (300mm)	Sump discharge up to 12 inch (300mm)
	D Sampling take off point 1 inch (25mm)	E 2 inch flange for heating
	Valve + Coupling connections tailored to meet your site-specific requirements	
Vent	4 inch top vent (on enclosed roof versions)	
Mounted Inspection Hatch	Visual contents inspection, accessible from top access platform	
Mixers	3nr 4kw 71 rpm mixers	
Required Power Supply	5 pin plug, 3 phase 32 Amp 21.9 Amp FLC (approx.)	
Access Platform	Fold out access platform c/w steps, handrails, safety swing gate	
Contents Gauging	Sight tube Radar (Telemetric)	
Heating	2 inch steam tubes (manifold pattern) 11.6m ² surface area *	
Manway Access	Low level, quick release, easy access hinged manlid	
Internal Coating	Chemical resistant epoxy lining (customer to supply MSDS for tank contents compatibility checking)	

*steam boiler required

TT40 AERATION TANK

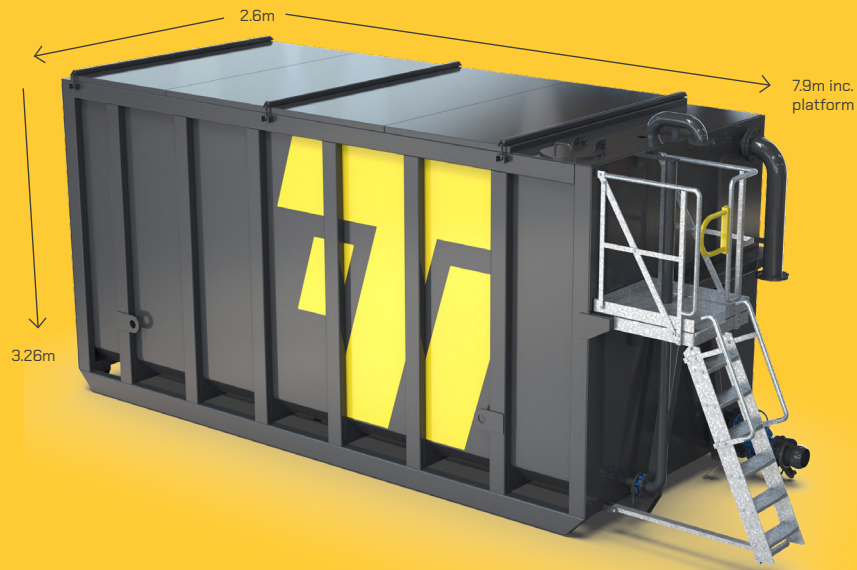

MEASUREMENTS & WEIGHT

Length	7,900mm including platform
Width	2,600mm
Height	3,260mm
Weight (empty)	6300kg (approx.)
Ground Pressure	193 kPa (approx.) - based on a liquid of SG1.12

Volume	40,000 Litres
	40m ³
	8,800 UK Gallons
Weight (loaded)	51100kg (approx.) - based on a liquid of SG1.12

MOBILISATION

Roll-On / Roll-Off, self-offload
Hiab self-offload
Crane lift via easy access, low level lifting points

APPLICATIONS

Civil engineering	Wastewater treatment
Chemical decom	Effluent processing
Industrial services	Shutdowns & turnarounds

TECHNICAL

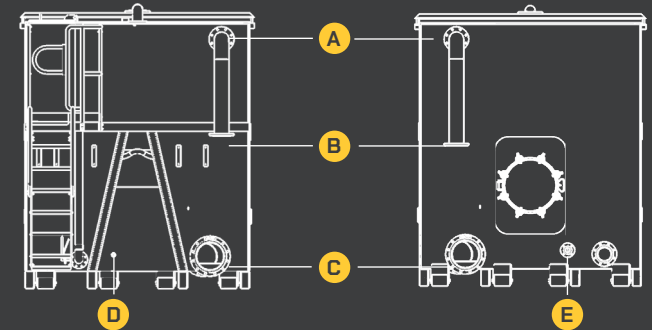

	Front	Rear
Connections	A High level 6 inch (150mm) connection	High level 6 inch (150mm) connection
	B Fill Pipe up to 6 inch (150mm)	Fill Pipe up to 6 inch (150mm)
	C Sump discharge up to 12 inch (300mm)	Sump discharge up to 12 inch (300mm)
	D Sampling take off point 1 inch (25mm)	E 2 inch flange
	Valve + Coupling connections tailored to meet your site-specific requirements	
Vent	4 inch top vent (on enclosed roof versions)	
Mounted Inspection Hatch	Visual contents inspection, accessible from top access platform	
Top Access Platform	Fold out access platform c/w steps, handrails, safety swing gate	
Contents Gauging	Sight tube	Radars (Telemetric)
Manway Access	Low level, quick release, easy access hinged manlid	
Aeration	25mm aeration pipework	
Internal Coating	Chemical resistant epoxy lining (customer to supply MSDS for tank contents compatibility checking)	

TT70 AERATION TANK



MEASUREMENTS & WEIGHT

Length	12,800mm including platform	Volume	70,000 Litres
Width	2,600mm		70m ³
Height	3,260mm		15,400 UK Gallons
Weight (empty)	10000kg (approx.)	Weight (loaded)	88400kg (approx.) - based on a liquid of SG1.12
Ground Pressure	215 kPa (approx.) - based on a liquid of SG1.12		

MOBILISATION

Roll-On / Roll-Off, self-offload
Hiab self-offload
Crane lift via easy access, low level lifting points

APPLICATIONS

Civil engineering	Wastewater treatment
Chemical decom	Effluent processing
Industrial services	Shutdowns & turnarounds



TECHNICAL

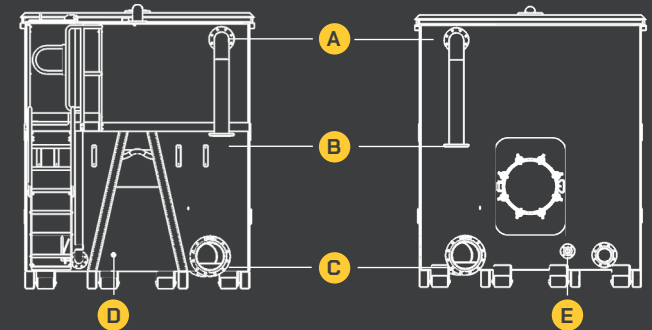

	Front	Rear
Connections	A High level 6 inch (150mm) connection B Fill Pipe up to 6 inch (150mm) C Sump discharge up to 12 inch (300mm) D Sampling take off point 1 inch (25mm)	A High level 6 inch (150mm) connection B Fill Pipe up to 6 inch (150mm) C Sump discharge up to 12 inch (300mm) E 2 inch flange
	Valve + Coupling connections tailored to meet your site-specific requirements	
Vent	4 inch top vent (on enclosed roof versions)	
Mounted Inspection Hatch	Visual contents inspection, accessible from top access platform	
Top Access Platform	Fold out access platform c/w steps, handrails, safety swing gate	
Contents Gauging	Sight tube Radar (Telemetric)	
Manway Access	Low level, quick release, easy access hinged manlid	
Internal Coating	Chemical resistant epoxy lining (customer to supply MSDS for tank contents compatibility checking)	

TT60-W WEIR TANK



MEASUREMENTS & WEIGHT

Length	12,800mm including platform	Volume	60,000 Litres
Width	2,600mm		60m ³
Height	3,100mm		13,200 UK Gallons
Weight (empty)	11000kg (approx.)	Weight (loaded)	78200kg (approx.) - based on a liquid of SG1.12
Ground Pressure	195 kPa (approx.) - based on a liquid of SG1.12		

MOBILISATION

Roll-On-Off self-offload
Hiab self-offload
Crane lift via easy access, low level lifting points

APPLICATIONS

Sewage treatment	Wastewater treatment
Flow regulation	Oil-water separation
Construction	Suspended solids removal



TECHNICAL

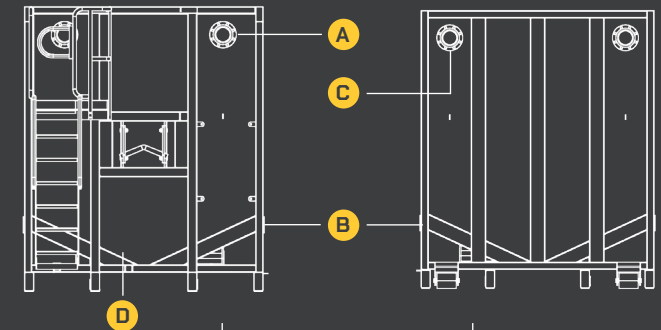

	Front	Rear	Rear
Connections	<p>A High level 6 inch (150mm) connection</p> <p>D Sampling take off point 1 inch (25mm)</p>	<p>B 3 No. 6 inch (150mm) low level sludge removal connections</p>	<p>C Sump discharge 6 inch (300mm) connection</p>
	Valve + Coupling connections tailored to meet your site-specific requirements		
Top Access Platform	Fold out access platform c/w steps, handrails, safety swing gate		
Contents Gauging	Sight tube Radar (Telemetric)		
Floor Design	V-shape bottom for efficient discharge and ease of cleaning		
Manway Access	Low level, quick release, easy access hinged manlid		
Internal Coating	Chemical resistant epoxy lining (customer to supply MSDS for tank contents compatibility checking)		

* specifications are indicative and may vary depending on product configuration and regional requirements.

VALVES

ASSOCIATED EQUIPMENT



TYPES
Float shut off valves
Butterfly valves
Ball valve
Knife gate valve
Other types available upon request

CONNECTED FITTINGS

ASSOCIATED EQUIPMENT



FACILITATES
Fire hydrant instantaneous couplings
PN16 and ANSI150 flanges
Bauer connections
MDPE
BSP thread
Other types available upon request

HOSES & HOSE RAMPS

ASSOCIATED EQUIPMENT

TYPES	SIZES AVAILABLE	CONNECTIONS AVAILABLE
Wire Armoured Suction/Discharge Hose	4" x 6m c/w	Flange & Bauer connections
	6" x 3m c/w	Flange & Bauer connections
Rigid Poly Pipe	6" x 6m c/w	Flange & Bauer connections
	4" x 6m c/w	Flange & Bauer connections
Heavy-Duty Layflat Discharge Hose	3" x 25m – 100m c/w	Bauer connections
	4" x 25m – 100m c/w	Bauer connections
Composite Flexi Hose	4" x 3 m	Flange & Bauer connections
	6" x 3 m	Flange & Bauer connections

Hose ramps are intended to allow liquid to safely flow, where there is a need to safeguard hoses and maintain access through pedestrian or vehicle traffic areas.

SIZES AVAILABLE	MEASUREMENTS & WEIGHT		CONNECTIONS AVAILABLE
300mm (12")	Length	5.2m	Valved with flange or bauer connections
	Width	2.1m	
	Weight	2250kg	
150mm (6")	Length	4.3m	Valved with flange or bauer connections
	Width	1.1m	
	Weight	1500kg	



CONTAINMENT BERMS

ASSOCIATED EQUIPMENT



MEASUREMENTS

Height	300mm
Width	3000mm
Length	13,500mm or 3000mm

FEATURES

Quick & easy to deploy
Single piece construction

SPECIFICATION

Ground Support	2400m x 1200mm 10mm Polyethylene mats
Material	Heavy Duty PVC coated fabric Highly chemical resistant and withstands long-term UV exposure
Hydrostatic Resistance	Withstands a broad range of chemicals including petroleum, oils, grease, and most acids
Temperature Range	-50 ° F - 160 ° F

GROUND MATS

ASSOCIATED EQUIPMENT



MEASUREMENTS

Thickness	100mm
Width	3000mm
Length	1000mm

FEATURES

Quick to deploy
Easy to set up

WELFARE PUMP

ASSOCIATED EQUIPMENT



Plug & play, portable temporary pump tank accommodating wastewater directly to a mains sewer or larger storage tanks, minimizing or eliminating waste tanker visits on sites.

MEASUREMENTS & WEIGHT

Height	900mm
Width	600mm
Length	1,100mm
Weight	120kg

SPECIFICATION

Max Pumping Distance	1,000m
Max. Pumping Height	20m
Pumping Main Required	63mm
Pump Type	Macerator
Automatic Flush Valve	Yes
Power Supply	230V
Power Rating	1.5kW
Rated Current	16A
Thermal Pump Protection	Yes
Waste Connection Invert	350mm from ground
Power Connection	16A Commando Plug

MOBILISATION

Fork/strap lifting pockets

TECHNICAL

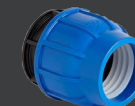
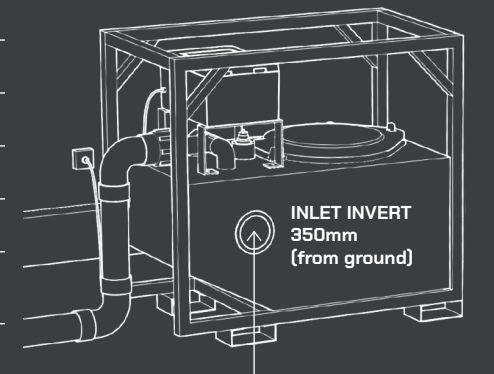

INDUSTRY SECTORS

WASTEWATER TREATMENT



TerraTank supports the wastewater industry with flexible, efficient temporary storage solutions designed for maintenance programmes, capital projects, and emergency response situations. From planned works to urgent operational challenges, our scalable systems help reduce disruption, and maintain continuity across critical wastewater operations.

ENERGY & RENEWABLES



In the high-performing industry of energy and renewables, process continuity, safety, and compliance are essential. We've worked with numerous clients to deliver liquid storage solutions tailored to the exact requirements of the industry.

INDUSTRIAL SERVICES & PETROCHEMICAL



Temporary liquid storage is essential to maintaining safe and efficient operations across the petrochemical sector. TerraTank delivers flexible and reliable storage solutions to support processing, maintenance, refinery, and industrial services operations.

MANUFACTURING



Manufacturing operations depend on efficient, resilient, and reliable effluent treatment. TerraTank provides versatile and scalable temporary storage for shutdowns, maintenance, changeovers, and unexpected interruptions, helping reduce downtime and maintain productivity.

CONSTRUCTION & MAJOR INFRASTRUCTURE



TerraTank delivers versatile storage solutions to support the construction, civil engineering, and infrastructure sectors. Supporting major infrastructure, utility, and pipeline projects, our solutions help maintain operational efficiency, programme continuity, and site compliance.

ENVIRONMENTAL RESPONSE



Environmental response situations require rapid, reliable liquid storage solutions to protect sites, safeguard personnel, support regulatory compliance, and to maintain operational continuity. From wastewater incidents to infrastructure failures, our modular storage solutions provide immediate support for time-critical scenarios.



01264 243 116 www.terratank.co.uk enquiries@terratank.co.uk

51 Central Way, Walworth Business Park, Andover, SP10 5AN
TerraTank[®] is a registered trade mark of Treloar Ltd. © 2026 Treloar Ltd.
All rights reserved. May 2026. TTCAT/080526/RevE.